

TUBE BANDIT™ - TB100 DIGITAL READOUT SYSTEM INSTRUCTIONS

Page 1 of 7

Read these instructions carefully before use!

Congratulations!

Thank you for purchasing the Tube Bandit Digital Readout System! This system provides a 1/10th degree accurate bend angle digital readout for JD Squared Model 3 and Pro Tools 105 and 105HD tube benders. Tube Bandit is proudly made in the USA using the finest quality materials.

Before You Begin

Please make sure you have all the components listed below:

- Display
- Display mounting bracket
- Center pin assembly
- Sensor assembly
- Sensor cable (not shown)
- Belt (not shown)
- Four screws for attaching display to mounting bracket (not shown)
- 3/32" hex wrench for use when attaching sensor and display to bender (not shown)
- You will also need 4-AA batteries to power the Tube Bandit (not included)

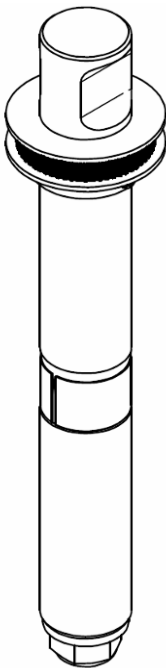

Center Pin
Assembly

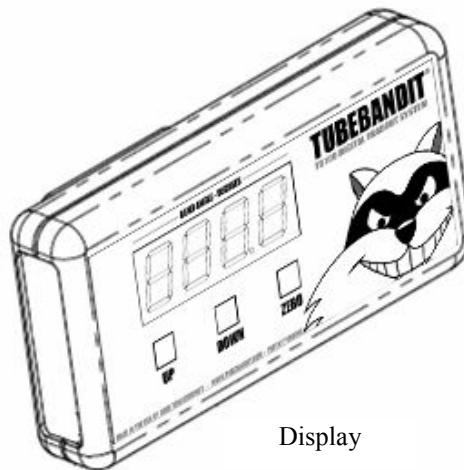

Display

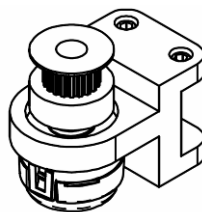

Sensor Assembly

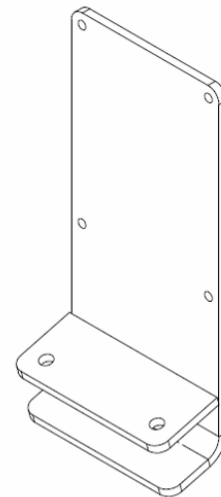

Display Mounting
Bracket

TUBE BANDIT™ - TB100 DIGITAL READOUT SYSTEM INSTRUCTIONS

Page 2 of 7

Disclaimer

Judd Tool Company will not be responsible for damages, loss of income or injuries resulting from the installation or use of this product. Use of this product is at the will and risk of the customer. Always wear appropriate personal protective equipment and use caution when operating machinery.

Installing Tube Bandit

Tools required for assembly:

- No. 1 Philips screwdriver
- 3/32" hex wrench (included)
- 5/8" open end wrench
- 11/16" wrench or ratchet

Step 1 (JD2 Model 3 only): If you have a JD2 Model 3 bender, you must remove the original degree wheel and mount from the lower fixed bender arm before installing Tube Bandit. Be aware that modifying your bender may affect the manufacturer's warranty. For Pro Tools model 105 and 105HD benders, the degree wheel does not need to be removed.

Step 2: Attach the display mounting bracket to the back of the display housing as shown below using four self-tapping screws provided and a No. 1 Philips screwdriver. Four holes are predrilled and the screws will self tap. **Do not over tighten.**

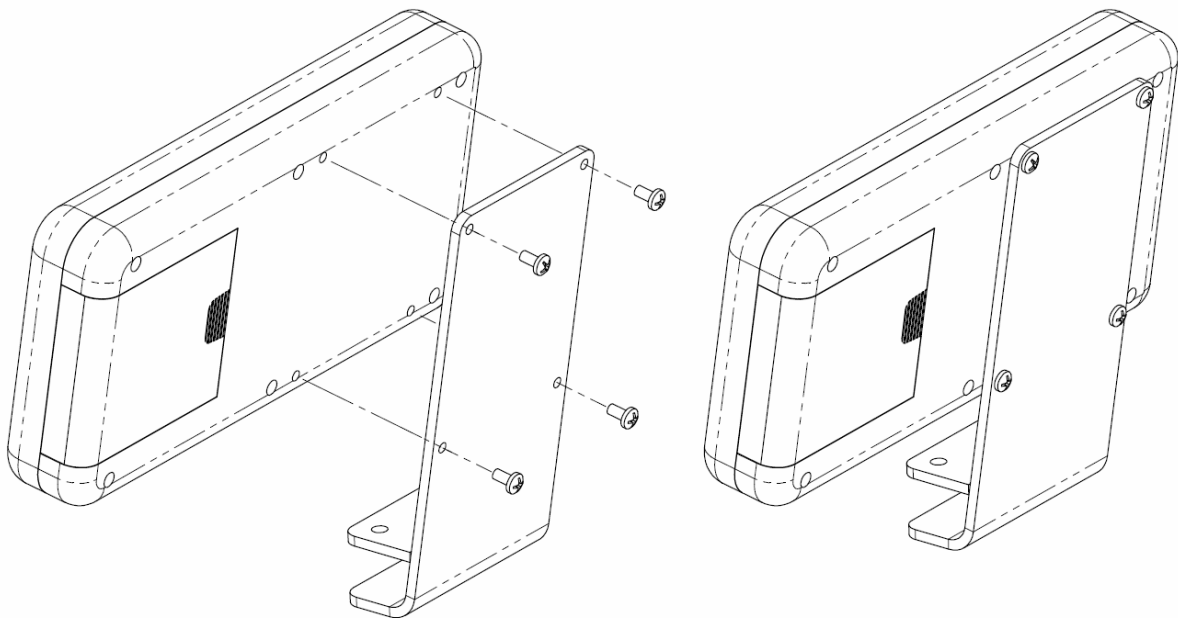

Step 3: Remove the battery cover from the back of the display and install four AA batteries. Make sure the batteries are installed in the correct direction. Replace the battery cover.

TUBE BANDIT™ - TB100 DIGITAL READOUT SYSTEM INSTRUCTIONS

Page 3 of 7

Step 4: With a die in place, insert the Tube Bandit center pin assembly in place of the bender's original center pin. Hold the center pin at the top using the open end of a 5/8" wrench. Use an 11/16" wrench or socket to tighten the nut at the bottom of the pin assembly until it locks with the die. **Do not tighten the center pin assembly unless a die is installed.**

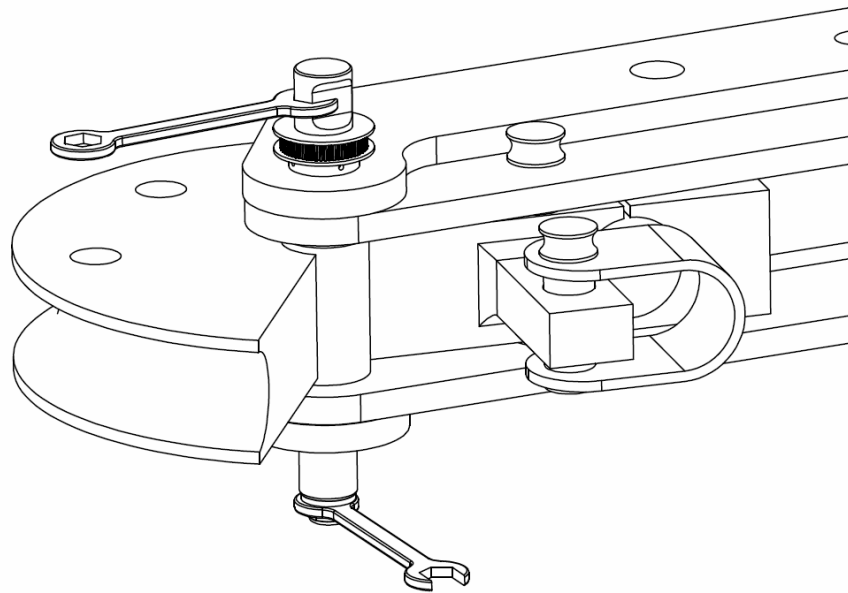

Step 5: Refer to the top view illustrations shown below. Position the sensor assembly on the side of the fixed bender arms. Place the belt between the two timing pulleys and slide the sensor along the bender arm until the belt has moderate tension. **Do not place heavy tension load on the belt or the sensor will bind.** Using a 3/32" hex wrench, tighten the two setscrews on the sensor bracket to lock it in place. Do not over tighten.

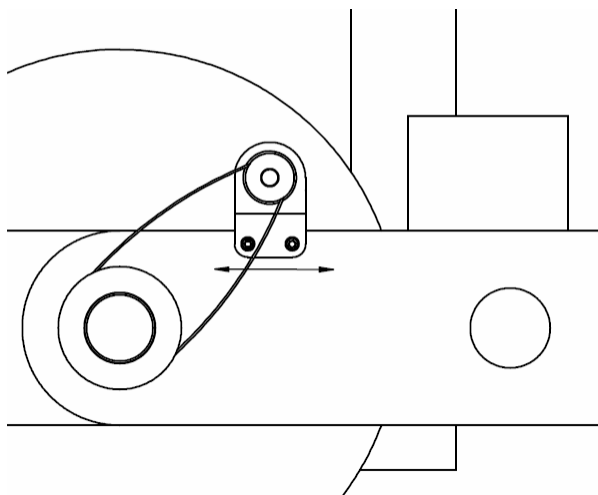

INCORRECT: Belt Too Loose

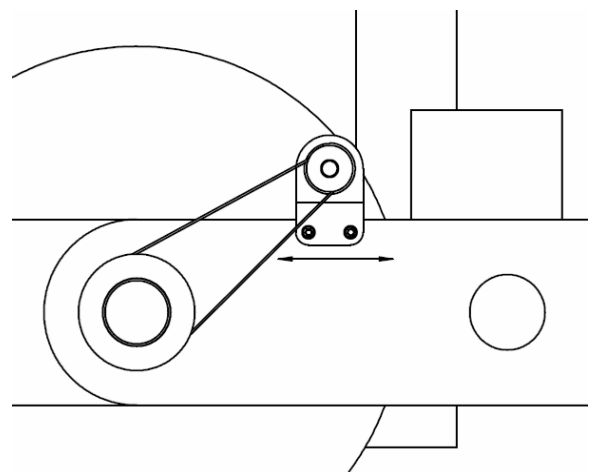

CORRECT: Moderate Belt Tension

TUBE BANDIT™ - TB100 DIGITAL READOUT SYSTEM INSTRUCTIONS

Page 4 of 7

Step 6: Mount the display to the upper bender arm as shown below. Position the display close enough to the sensor so the sensor cable will reach without tension. Tighten the two setscrews on the display mounting bracket to clamp it onto the arm of the bender. **Do not over tighten.**

Step 7: Connect the sensor to the display using the included sensor cable. The ends of the connectors will only fit one way. **Do not force the connectors or you may cause damage.**

This completes the installation.

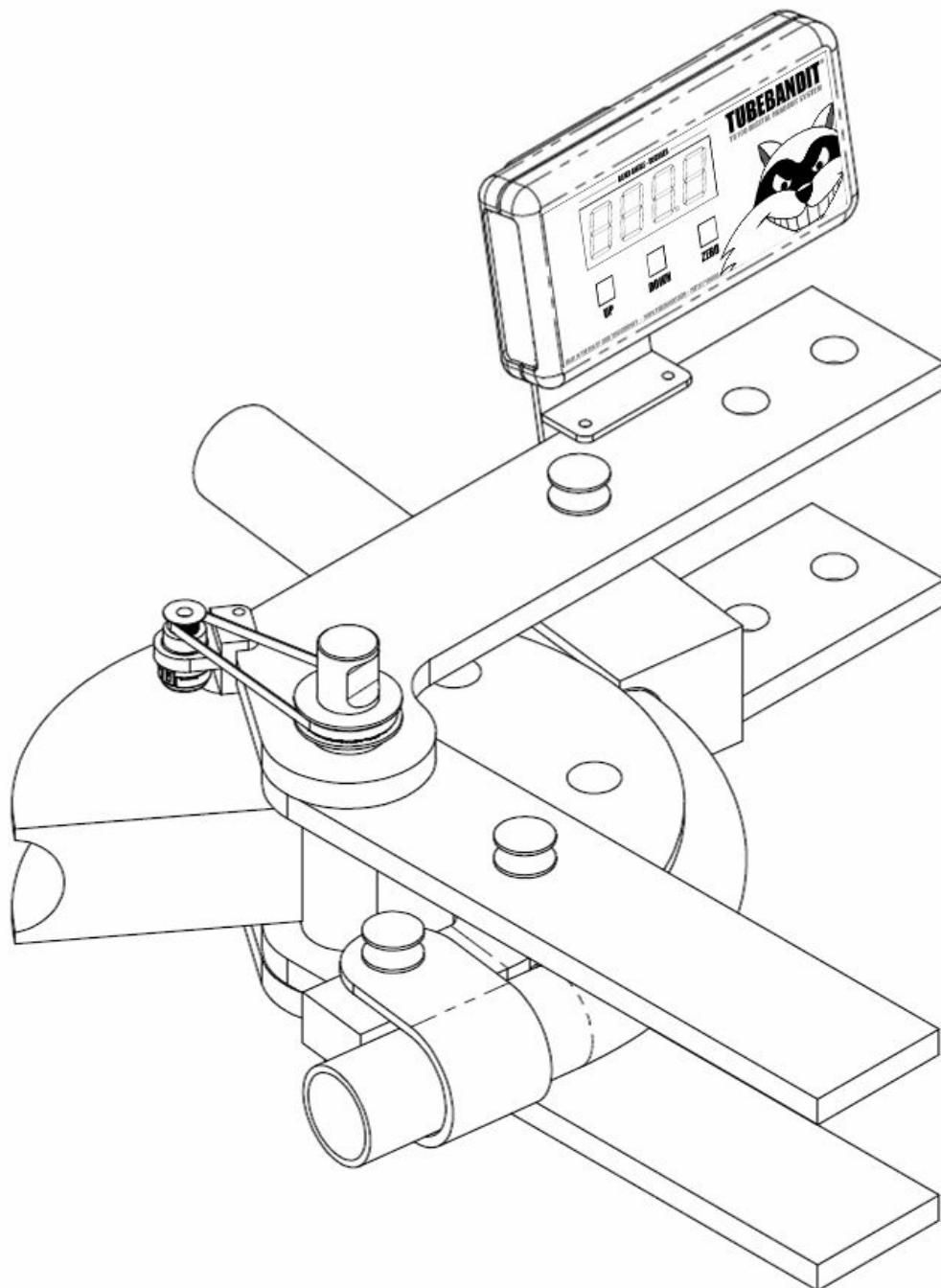

TUBE BANDIT™ - TB100 DIGITAL READOUT SYSTEM

INSTRUCTIONS

Page 5 of 7

Changing Dies

To change dies, loosen the set screws on the sensor assembly bracket, remove the belt, and loosen the nut at the bottom of the center pin assembly. The pin assembly may remain locked in the die even though the nut is loose. To unlock the center pin assembly, use a 5/8" wrench on the top of the pin (the two finger flats) and twist the pin while keeping the die stationary (it may help to keep the die drive pin installed). This should free the center pin for removal.

Powering On and Establishing Zero

Once the Tube Bandit is installed, turn on the display using the power switch on the left side. The display will flash "0.0". Put a piece of tubing in your bender, place light tension on the tube to remove free play, then hold the ZERO button until the display no longer flashes. This will establish your zero reference position. If you would like to offset for springback, you can press the UP or DOWN button until the display shows a negative angle equal to your springback angle. Holding the UP or DOWN buttons will rapidly increase or decrease the angle.

If you are making multiple bends with the same dies and tubing, you do not need to re-zero between bends. However you must zero Tube Bandit each time it is powered on.

Determining Springback

When bending, the most accurate angle measurement will be when the tubing has full pressure against it. Due to the change in centerline radius when pressure is released, Tube Bandit will not correctly measure the angle of the tubing after springback. For example, let's say you bend tubing until the display shows a maximum of angle of 90.0 degrees. After you release pressure, the tubing will spring back some and the display may show a different angle, such as 80.8 degrees. The 80.8 degree angle IS NOT the angle of the tubing after springback. To determine the actual angle of the tubing after springback, you will need to remove the tubing from your bender and measure with some other means (such as a protractor). If you took this piece of tubing out of the machine and measured 85.5 degrees, your springback angle would be 4.5 degrees ($90.0 - 85.5 = 4.5$ degrees).

Once you determine the springback angle for a given tubing size or material, there are two common ways to compensate when bending:

Method 1: Add the springback angle to your desired angle and bend until the display shows that angle. For example, if you want a 90 degree bend and your springback angle is 4.5 degrees, bend until the display shows a maximum 94.5 degrees ($90 + 4.5 = 94.5$ degrees).

Method 2: Offset your zero by the springback angle prior to bending. For example, if your springback angle is 4.5 degrees and you want a bend angle of 90 degrees, first zero the Tube Bandit then use the UP or DOWN buttons until the display shows -4.5 degrees. Next, bend until the display shows the desired angle of 90 degrees.

Springback may vary with different tube sizes, materials, and even batches of tubing. Check the springback angle periodically to ensure the most accurate bends.

TUBE BANDIT™ - TB100 DIGITAL READOUT SYSTEM

INSTRUCTIONS

Page 6 of 7

Low Battery Warning

The display digits will flash twice every five seconds when the batteries are too low for reliable operation. **Replace your batteries as soon as possible.** Low batteries may cause the Tube Bandit to incorrectly read the sensor or reset to zero during a bend. The accuracy of Tube Bandit can not be assured when the batteries are low.

Battery Saving Feature

If the Tube Bandit is left idle for more than 10 minutes, the display digits will go blank to conserve batteries. The decimal place will remain lit to indicate the Tube Bandit is on and still measuring bend angle. If you move the bender arms or press the UP or DOWN buttons, the digits will reappear. You will not need to rezero the display.

To get the most out of your batteries, turn Tube Bandit off when it is not in use.

Rollover Angle

Tube Bandit will read between -99.9 degrees and 260.0 degrees. When the angle increases above 260.0 degrees it will roll over to -99.9 degrees and continue to increase. When the angle decreases below -99.9 degrees it will roll over to 260.0 degrees and continue to decrease.

How to Care for Tube Bandit

Never leave Tube Bandit outside or in direct sunlight for long periods of time. Tube Bandit is not waterproof or dustproof. Cover or store Tube Bandit when not in use. The center pin assembly should be disassembled and lubricated periodically to prevent sticking and proper operation.

Periodically, verify the accuracy of the Tube Bandit using a second tool such as a protractor or manual angle finder.

Warranty

We strive to build the most accurate and reliable tools for hobbyists and professionals. Judd Tool Company will replace or provide a refund for defective components exchanged within the first 30 days of purchase. Components must be returned in the condition they were sold. Damage resulting from improper installation or misuse as determined by Judd Tool Company will void this warranty.

Questions or Concerns

If you have any questions or concerns about this product:

Visit our website: www.tubebandit.com
Or call: (805) 512-7800

TUBE BANDIT™ - TB100 DIGITAL READOUT SYSTEM INSTRUCTIONS

Troubleshooting

Problem	Cause/Solution
Display flashes every 5 seconds	<ul style="list-style-type: none"> • Batteries low; replace or recharge • Batteries loose; press firmly into position • Check battery orientation
Display goes blank after 10 minutes	<ul style="list-style-type: none"> • Battery save feature is active; move bender to wake Tube Bandit
Display angle does not change with movement of bender	<ul style="list-style-type: none"> • Sensor pulley set screws loose; tighten set screws • Sensor cable is not firmly connected; check connection • Pin assembly is not tight; check to see that pin assembly rotates with die • Batteries are extremely low; replace batteries
Display angle changes rapidly and randomly with vibration	<ul style="list-style-type: none"> • Sensor cable is not firmly connected; check connection
Display angle seems to stick and jump while bending	<ul style="list-style-type: none"> • Sensor pulley set screws loose; tighten set screws • Belt is too tight and sensor is binding; loosen belt tension by moving the sensor assembly
Pin assembly is difficult to remove from die	<ul style="list-style-type: none"> • Make sure flange nut is loose • Rotate assembly to free it from die • Check for wear on tapered section of pin and polish if necessary • Lubricate tapered section of pin • Check alignment of bender arms

Custom Installations

Longer sensor cables are available for custom installations of the Tube Bandit display. Visit our website to inquire. The dimensions below can be used for making your own mounting bracket.

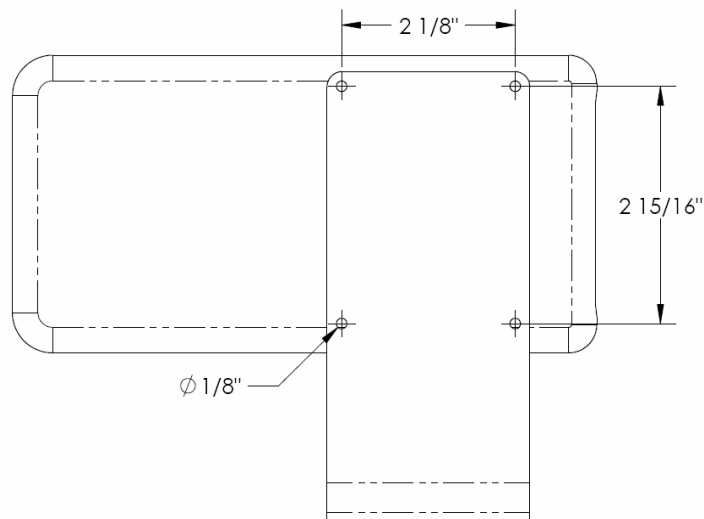

Thank you for your Tube Bandit purchase! We appreciate your business.